



13130 56th Court, Suite 604
Clearwater, Florida
33760-4021 USA
Voice: (727) 592-0303
Fax: (727) 592-0503

DOCUMENT NO. **JMIH-CAT-002**

JORMAC AEROSPACE, INC.

TIE-ROD ASSEMBLIES

&

ATTACHMENTS

CATALOG



13130 56th Court, Suite 604
Clearwater, Florida 33760-4018
United States Of America

Telephone: (727) 592-0303
FAX: (727) 592-0503

INDEX:

	Page
1. Standard Tie-Rod Assemblies.....	1
2. Standard Monument Seat Track	2
3. Standard Monument/Floor Panel Attachment	3
4. Standard Monument Attachment	4
5. Standard Monument Attachment	5
6. Standard Bulkhead Attachment	6
7. Standard Sideledge Attachment, Lower	7
8. Standard Sideledge Attachment, Lower	8
9. Standard B737 Stringer Longitudinal Attachment	9
10. Standard B737 Frame Lateral Attachment	10
11. Standard Bulkhead Lower Attachment, Seat Track.....	11
12. Standard Bulkhead Attachment, Floor Panel	12
13. Standard Monument Attachment	13
14. Standard Monument Attachment	14
15. Standard Bulkhead Attachment, Non-Isolated	15





13130 56th Court, Suite 604
 Clearwater, Florida 33760-4018
 United States Of America

Telephone: (727) 592-0303
 FAX: (727) 592-0503

DWG NO.	JMDS-TR1-010	SH	1	REV	TR
---------	--------------	----	---	-----	----

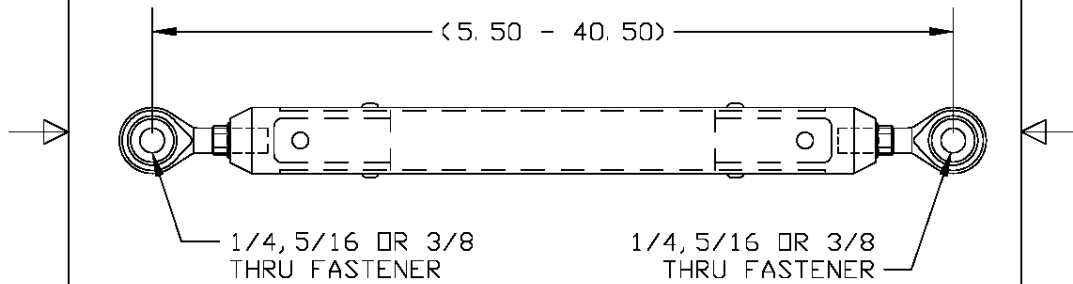
1. LOAD RANGE: 1000-5000 LBS.
2. LENGTH 5.50 - 40.50 INCHES.
3. TENSION ONLY OR TENSION/COMPRESSION APPLICATIONS.
4. 1/4, 5/16, 3/8 PIN DIAMETERS SUPPORTED.
5. MISMATCHING ROD-ENDS PERMITTED.
6. ALL HDWR SHOWN INCLUDED UNLESS OTHERWISE NOTED.



			CONTRACT NUMBER/ PROGRAM IDENTIFIER JMDS		JORMAC AEROSPACE  <small>13130 56TH COURT, SUITE 604 CLEARWATER, FLORIDA 33760-4018 USA (727) 592-0303 FAX: (727) 592-0503</small>		
			DRAWN				
			DESIGN		STANDARD TIE-ROD		
			STRESS		ASSEMBLIES		
			M&P		SIZE		
			CHECK		A	FILE TYPE	
			PROJECT		ACAD	DWG NO.	
DASH	NEXT ASSY	USED ON	RELEASE		JMDS-TR1-010		
APPLICATION			OPEN		SCALE: NONE	FILE: JMDS-TIEROD, 001A	
					SHEET 1 OF 1		

JORMAC FORM
 NO. JM4001-TL

[BACK TO INDEX](#)



13130 56th Court, Suite 604
 Clearwater, Florida 33760-4018
 United States Of America

Telephone: (727) 592-0303
 FAX: (727) 592-0503

DWG NO. JMCS-010-010 SH 1 REV 1R

1. DESIGN LIMIT DEPENDENT ON PANEL CONFIGURATION. CONVENTIONAL PANEL TYPES WILL YIELD VERTICAL CAPABILITY OF 1500-4000 LBS.
2. ALL HARDWARE SHOWN INCLUDED UNLESS OTHERWISE NOTED.

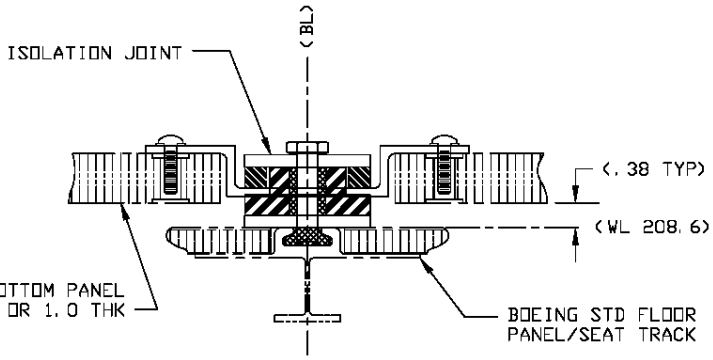
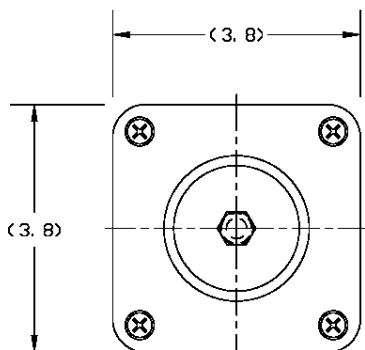

MONUMENT BOTTOM PANEL
 .50, .75 OR 1.0 THK

BOEING STD FLOOR
 PANEL/SEAT TRACK

- 001 FOR .75THK BOTTOM PNL.
- 031 FOR .50THK BOTTOM PNL
- 035 FOR 1.00THK BOTTOM PNL.

			CONTRACT NUMBER/ PROGRAM IDENTIFIER JMIH		JORMAC AEROSPACE  <small>13130 56TH COURT, SUITE 604 CLEARWATER, FLORIDA 33760-4018 USA (727) 592-0303 FAX: (727) 592-0503</small>		
			DRAWN				DWG TITLE
			DESIGN		STANDARD MONUMENT/ SEAT TRACK ATTACHMENT		
			STRESS				
			M&P				
			CHECK				
			PROJECT				
DASH	NEXT ASSY	USED ON	RELEASE		SIZE A	FILE TYPE ACAD	DWG NO. JMCS-010-010
APPLICATION			OPEN		SCALE: NONE	FILE: JMCS-STANDARDS_001A	SHEET 1 OF 14

JORMAC FORM
 NO. JM4001-TL

[BACK TO INDEX](#)



13130 56th Court, Suite 604
 Clearwater, Florida 33760-4018
 United States Of America

Telephone: (727) 592-0303
 FAX: (727) 592-0503

DWG NO. JMCS-010-010 SH 2 REV 1R

1. DESIGN LIMIT DEPENDENT ON PANEL CONFIGURATION. CONVENTIONAL PANEL TYPES WILL YIELD VERTICAL CAPABILITY OF 1200-1600 LBS.
2. ALL HARDWARE SHOWN INCLUDED UNLESS OTHERWISE NOTED.
3. DEM FLOOR PANEL LOADS ARE A FUNCTION OF LOCATION AND MUST BE ADDRESSED SEPARATELY.

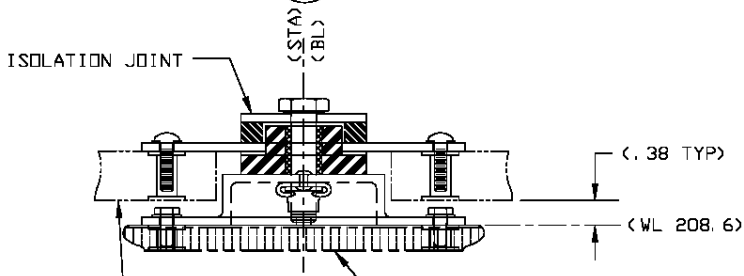
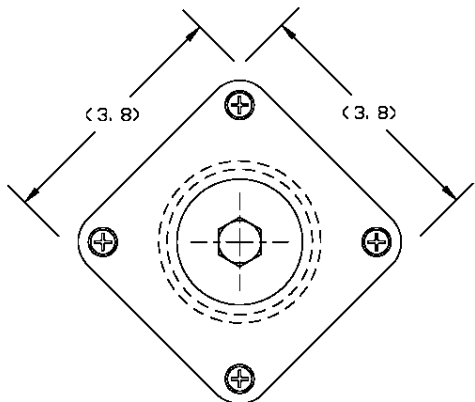

MONUMENT BOTTOM PANEL
 .50, .75 OR 1.0 THK

STD BOEING FLOOR PANEL

-003 FOR .75THK BOTTOM PANEL
 -033 FOR .50THK BOTTOM PANEL
 -037 FOR 1.0THK BOTTOM PANEL

			CONTRACT NUMBER/ PROGRAM IDENTIFIER JMIH		JORMAC AEROSPACE  <small>13130 56TH COURT, SUITE 604 CLEARWATER, FLORIDA 33760-4018 USA (727) 592-0303 FAX (727) 592-0503</small>		
			DRAWN				
			DESIGN		DWG TITLE STANDARD MONUMENT/ FLR PNL ATTACHMENT		
			STRESS				
			M&P				
			CHECK				
			PROJECT				
DASH	NEXT ASSY	USED ON	RELEASE		SIZE A	FILE TYPE ACAD	DWG NO. JMCS-010-010
APPLICATION				OPEN	SCALE: NONE	FILE: JMCS-STANDARDS_002A	SHEET 2 OF 14

JORMAC FORM
 NO. JM4001-TL

[BACK TO INDEX](#)



13130 56th Court, Suite 604
 Clearwater, Florida 33760-4018
 United States Of America

Telephone: (727) 592-0303
 FAX: (727) 592-0503

DWG NO. JMCS-010-010 SH 3 REV IR

1. DESIGN LIMIT DEPENDENT ON PANEL CONFIGURATION. CONVENTIONAL PANEL TYPES WILL YIELD VERTICAL CAPABILITY OF 1300-2000 LBS.
2. ALL HARDWARE SHOWN INCLUDED UNLESS OTHERWISE NOTED.

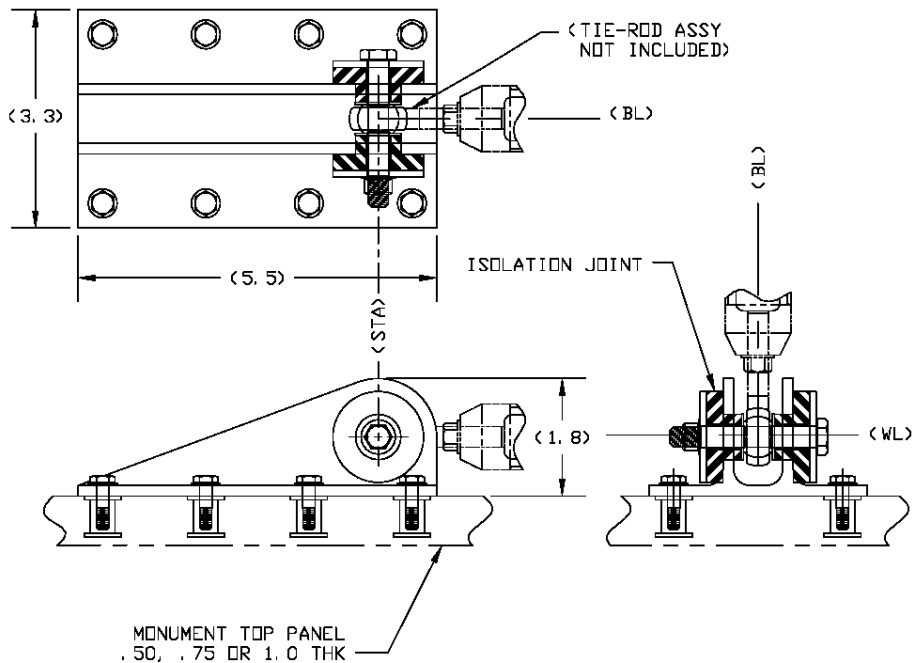

-005 MONUMENT FWD/AFT RESTRAINT

			CONTRACT NUMBER/ PROGRAM IDENTIFIER JMIH		JORMAC AEROSPACE  <small>13130 56TH COURT, SUITE 604 CLEARWATER, FL 33760-4018 USA (727) 592-0303 FAX: (727) 592-0503</small>		
			DRAWN				DWG TITLE
			DESIGN		STANDARD MONUMENT		
			STRESS		ATTACHMENT		
			M&P				
			CHECK				
			PROJECT				
DASH	NEXT ASSY	USED ON	RELEASE		SIZE	FILE TYPE	DWG NO.
			OPEN		A	ACAD	JMCS-010-010
APPLICATION					SCALE: NONE	FILE: JMCS-STANDARDS_003A	SHEET 3 OF 14

JORMAC FORM
 NO. JM4001-TL

[BACK TO INDEX](#)



13130 56th Court, Suite 604
 Clearwater, Florida 33760-4018
 United States Of America

Telephone: (727) 592-0303
 FAX: (727) 592-0503

DWG NO. JMCS-010-010 SH 4 REV IR

- DESIGN LIMIT DEPENDENT ON PANEL CONFIGURATION. CONVENTIONAL PANEL TYPES WILL YIELD CAPABILITY OF UP TO 1500 LBS.
- ALL HARDWARE SHOWN INCLUDED UNLESS OTHERWISE NOTED.

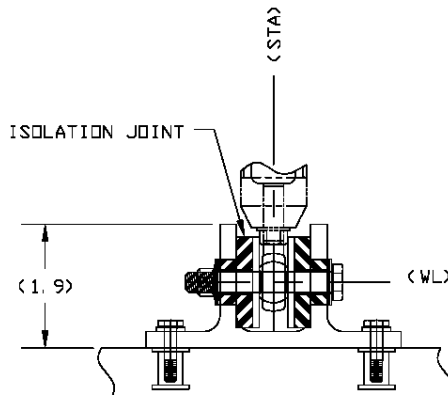
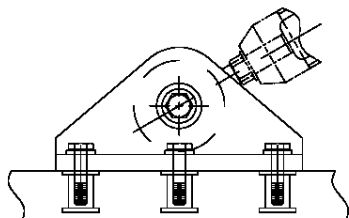
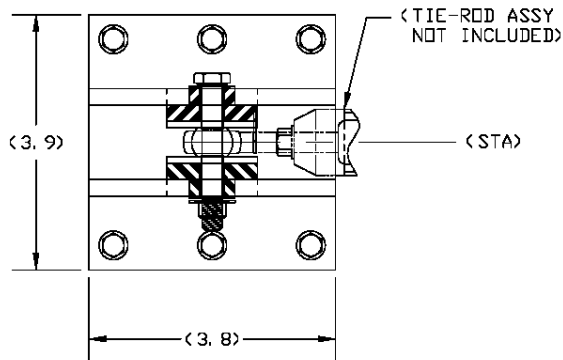

MONUMENT TOP PANEL
 .50, .75 OR 1.0 THK

-007 MONUMENT LATERAL RESTRAINT

			CONTRACT NUMBER/ PROGRAM IDENTIFIER JMIH		JORMAC AEROSPACE  13130 56TH COURT, SUITE 604 CLEARWATER, FL 33760-4018 USA (727) 592-0303 FAX: (727) 592-0503	
			DRAWN			
			DESIGN		DWG TITLE	
			STRESS		STANDARD MONUMENT	
			M&P		ATTACHMENT	
			CHECK		SIZE	FILE TYPE
			PROJECT		A	ACAD
DASH	NEXT ASSY	USED ON	RELEASE		DWG NO.	JMCS-010-010
APPLICATION			OPEN		SCALE:	NONE
					FILE:	JMCS-STANDARDS_004A
					SHEET 4 OF 14	

JORMAC FORM
 NO. JM4001-TL

[BACK TO INDEX](#)



13130 56th Court, Suite 604
 Clearwater, Florida 33760-4018
 United States Of America

Telephone: (727) 592-0303
 FAX: (727) 592-0503

DWG NO. JMCS-010-010 SH 5 REV 1R

1. DESIGN LIMIT DEPENDENT ON PANEL CONFIGURATION. CONVENTIONAL PANEL TYPES WILL YIELD CAPABILITY OF UP TO 1500 LBS.
2. ALL HARDWARE SHOWN INCLUDED UNLESS OTHERWISE NOTED.

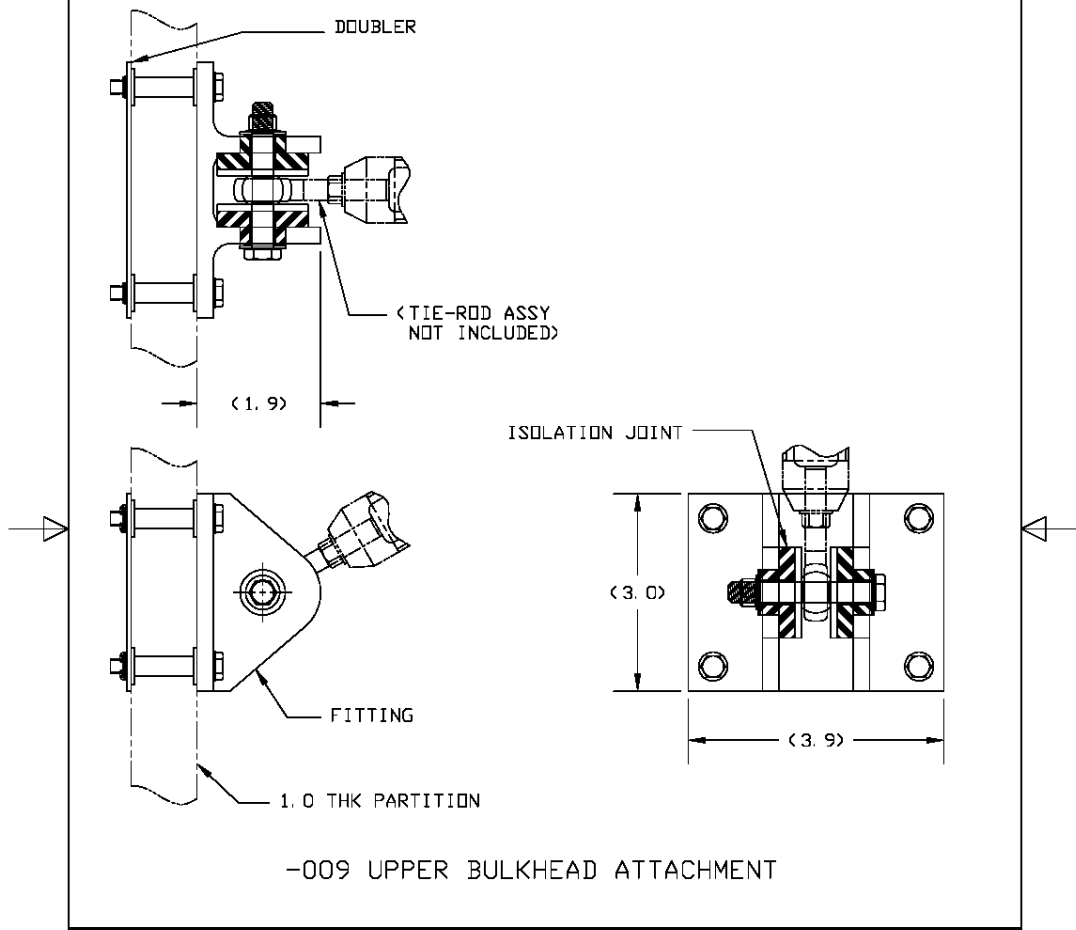

-009 UPPER BULKHEAD ATTACHMENT

			CONTRACT NUMBER/ PROGRAM IDENTIFIER JMIH		JORMAC AEROSPACE  <small>13130 56TH COURT, SUITE 604 CLEARWATER, FL 33760-4018 USA (727) 592-0303 FAX: (727) 592-0503</small>		
			DRAWN				DWG TITLE
			DESIGN		STANDARD BULKHEAD		
			STRESS		ATTACHMENT		
			M&P				
			CHECK				
			PROJECT				
DASH	NEXT ASSY	USED ON	RELEASE		SIZE A	FILE TYPE ACAD	DWG NO. JMCS-010-010
APPLICATION			OPEN		SCALE: NONE	FILE: JMCS-STANDARDS_005A	SHEET 5 OF 14

JORMAC FORM
 NO. JM4001-TL

[BACK TO INDEX](#)



13130 56th Court, Suite 604
 Clearwater, Florida 33760-4018
 United States Of America

Telephone: (727) 592-0303
 FAX: (727) 592-0503

DWG NO. JMCS-010-010 SH 6 REV IR

1. DESIGN LIMIT 200 LBS.
2. ALL HARDWARE SHOWN INCLUDED UNLESS OTHERWISE NOTED.

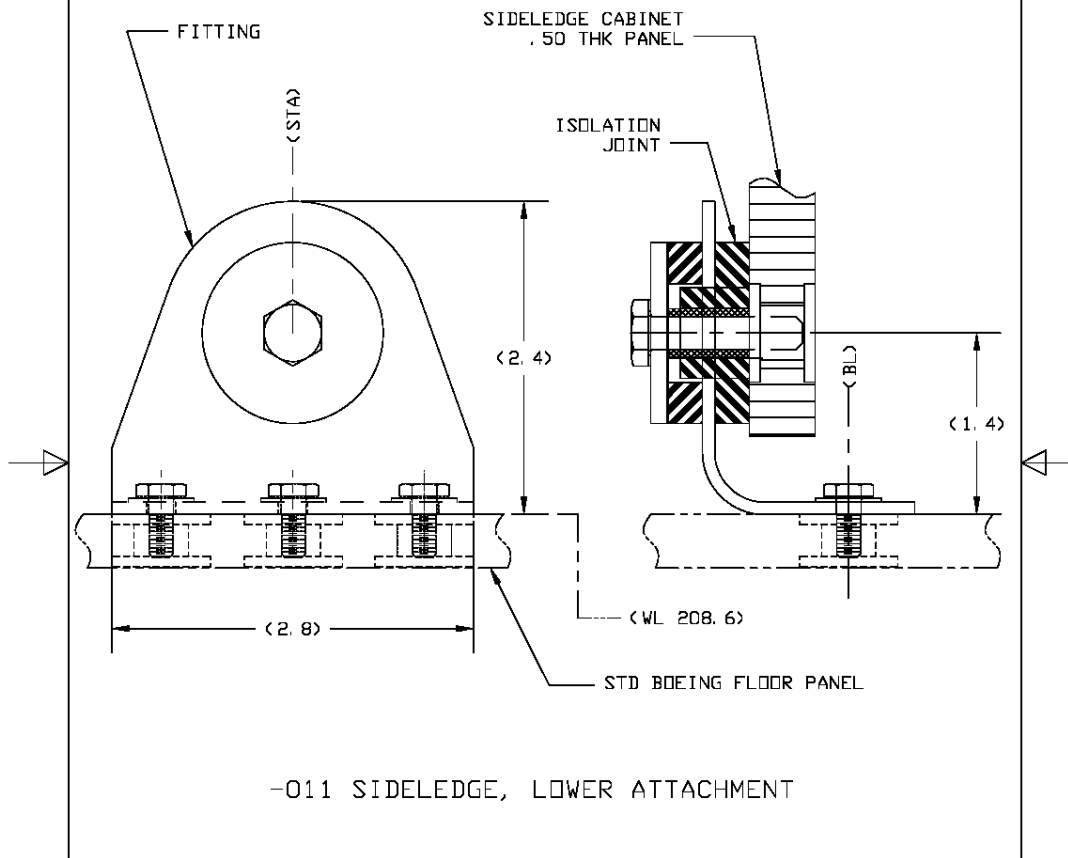

-011 SIDELEDGE, LOWER ATTACHMENT

			CONTRACT NUMBER/ PROGRAM IDENTIFIER JMTH		JORMAC AEROSPACE  <small>13130 56TH COURT, SUITE 604 CLEARWATER, FLORIDA 33760-4018 USA (727) 592-0303 FAX (727) 592-0503</small>		
			DRAWN				DWG TITLE
			DESIGN		STANDARD SIDELEDGE		
			STRESS		ATTACHMENT, LWR.		
			M&P				
			CHECK				
			PROJECT				
DASH	NEXT ASSY	USED ON	RELEASE		SIZE A	FILE TYPE ACAD	DWG NO. JMCS-010-010
APPLICATION			OPEN		SCALE: NONE	FILE: JMCS-STANDARDS_006A	SHEET 6 OF 14

JORMAC FORM
 NO. JM4001-TL

[BACK TO INDEX](#)



13130 56th Court, Suite 604
 Clearwater, Florida 33760-4018
 United States Of America

Telephone: (727) 592-0303
 FAX: (727) 592-0503

DWG NO. JMCS-010-010 SH 7 REV IR

1. DESIGN LIMIT 60-150 LBS LAT/FWD ONLY.
2. ALL HARDWARE SHOWN INCLUDED UNLESS OTHERWISE NOTED.

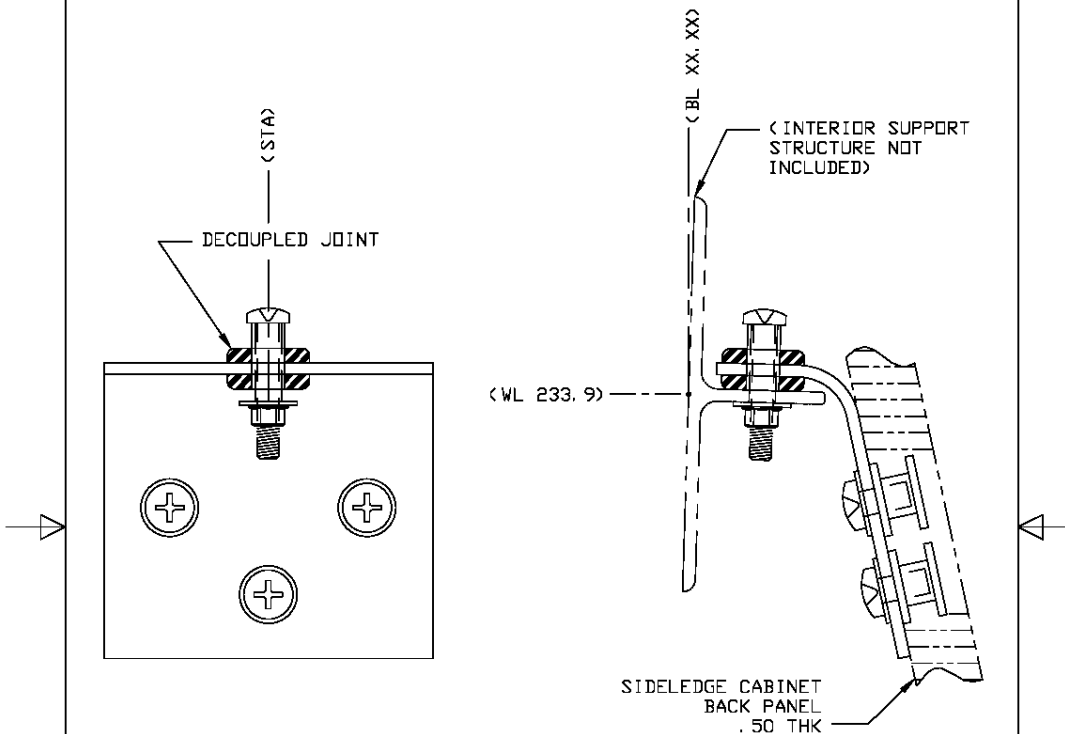

-013 UPPER SIDELEDGE ATTACHMENT, LWR.

			CONTRACT NUMBER/ PROGRAM IDENTIFIER JM1H		 <small>13130 56TH COURT, SUITE 604 CLEARWATER, FL 33760-4018 USA (727) 592-0303 FAX (727) 592-0503</small>	
			DRAWN		DWG TITLE STANDARD SIDELEDGE ATTACHMENT, LWR.	
			DESIGN			
			STRESS			
			M&P			
			CHECK			
			PROJECT			
DASH	NEXT ASSY	USED ON	RELEASE		SIZE	FILE TYPE
			OPEN		A	ACAD
APPLICATION					DWG NO.	JMCS-010-010
					SCALE: NONE	FILE: JMCS-STANDARDS, 007A SHEET 7 OF 14

JORMAC FORM
 NO. JM4001-TL

[BACK TO INDEX](#)



13130 56th Court, Suite 604
 Clearwater, Florida 33760-4018
 United States Of America

Telephone: (727) 592-0303
 FAX: (727) 592-0503

DWG NO. JMCS-010-010 SH 8 REV 1R

1. DESIGN LIMIT DEPENDENT ON TIE ROD ANGLE.
 NOMINAL RANGE 1100-2000 LBS FOR ANGLE UP TO 45°.
2. ALL HARDWARE SHOWN INCLUDED UNLESS OTHERWISE NOTED.

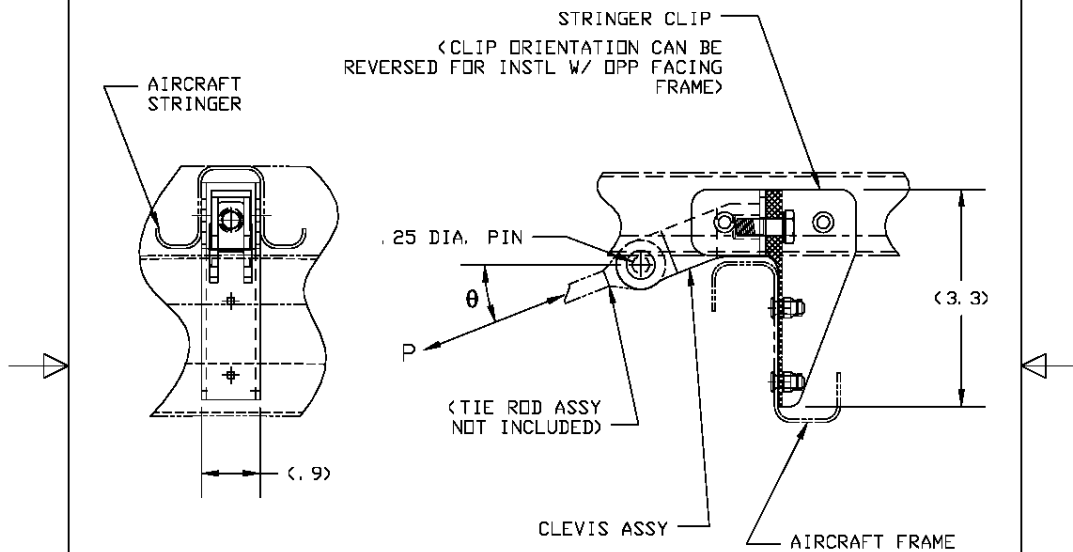

-015 STRINGER ATTACHMENT, FWD/AFT

			CONTRACT NUMBER/ PROGRAM IDENTIFIER JMIH		JORMAC AEROSPACE 13130 56TH COURT, SUITE 604 CLEARWATER, FL 33760-4018 USA (727) 592-0303 FAX: (727) 592-0503	
			DRAWN		DWG TITLE	
			DESIGN		STANDARD B737 STRINGER LONGITUDINAL ATTACHMENT	
			STRESS			
			M&P			
			CHECK			
			PROJECT			
DASH	NEXT ASSY	USED ON	RELEASE		SIZE A	FILE TYPE ACAD
APPLICATION			OPEN		DWG NO. JMCS-010-010	
				SCALE: NONE	FILE: JMCS-STANDARDS_008A	SHEET 8 OF 14

JORMAC FORM
 NO. JM4001-TL

[BACK TO INDEX](#)



13130 56th Court, Suite 604
 Clearwater, Florida 33760-4018
 United States Of America

Telephone: (727) 592-0303
 FAX: (727) 592-0503

DWG NO. JMCS-010-010 SH 9 REV IR

1. DESIGN LIMIT DEPENDENT ON TIE ROD ANGLE.
 NOMINAL RANGE 500-1000 LBS FOR ANGLE UP TO 90°.
2. ALL HARDWARE SHOWN INCLUDED UNLESS OTHERWISE NOTED.

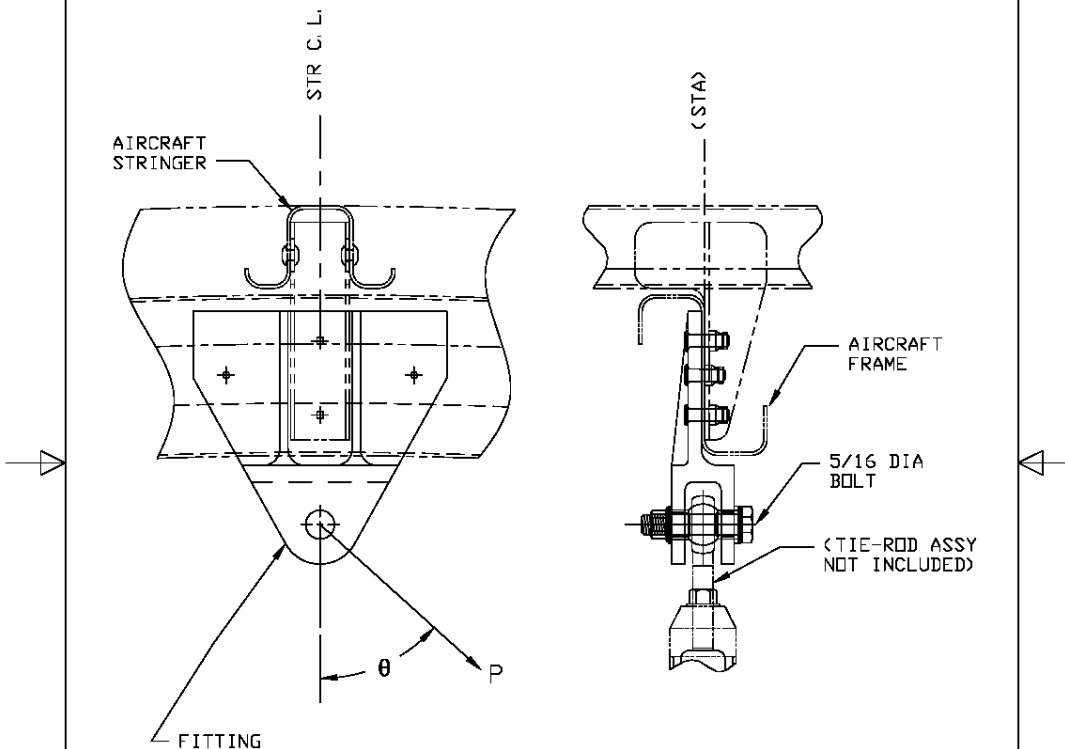

-017 FRAME ATTACHMENT, LATERAL

			CONTRACT NUMBER/ PROGRAM IDENTIFIER JMIH		JORMAC AEROSPACE  13130 56TH COURT, SUITE 604 CLEARWATER, FL 33760-4018 USA (727) 592-0303 FAX: (727) 592-0503		
			DRAWN				
			DESIGN		DWG TITLE STANDARD B737 FRAME LATERAL ATTACHMENT		
			STRESS				
			M&P				
			CHECK				
			PROJECT				
DASH	NEXT ASSY	USED ON	RELEASE		SIZE A	FILE TYPE ACAD	DWG NO. JMCS-010-010
APPLICATION				OPEN	SCALE: NONE	FILE: JMCS-STANDARDS_009A	SHEET 9 OF 14

JORMAC FORM
 NO. JM4001-TL

[BACK TO INDEX](#)



13130 56th Court, Suite 604
 Clearwater, Florida 33760-4018
 United States Of America

Telephone: (727) 592-0303
 FAX: (727) 592-0503

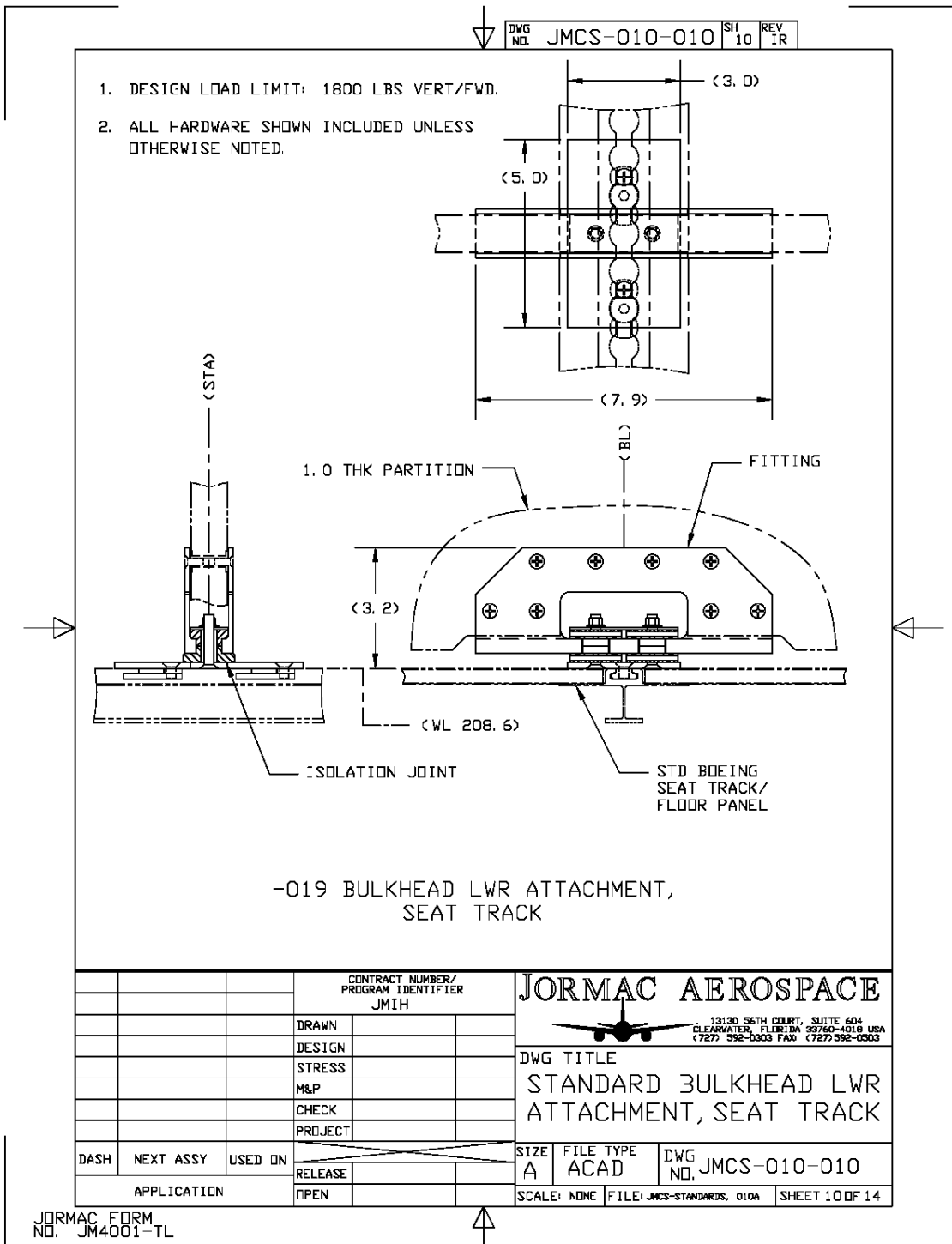

[BACK TO INDEX](#)



13130 56th Court, Suite 604
 Clearwater, Florida 33760-4018
 United States Of America

Telephone: (727) 592-0303
 FAX: (727) 592-0503

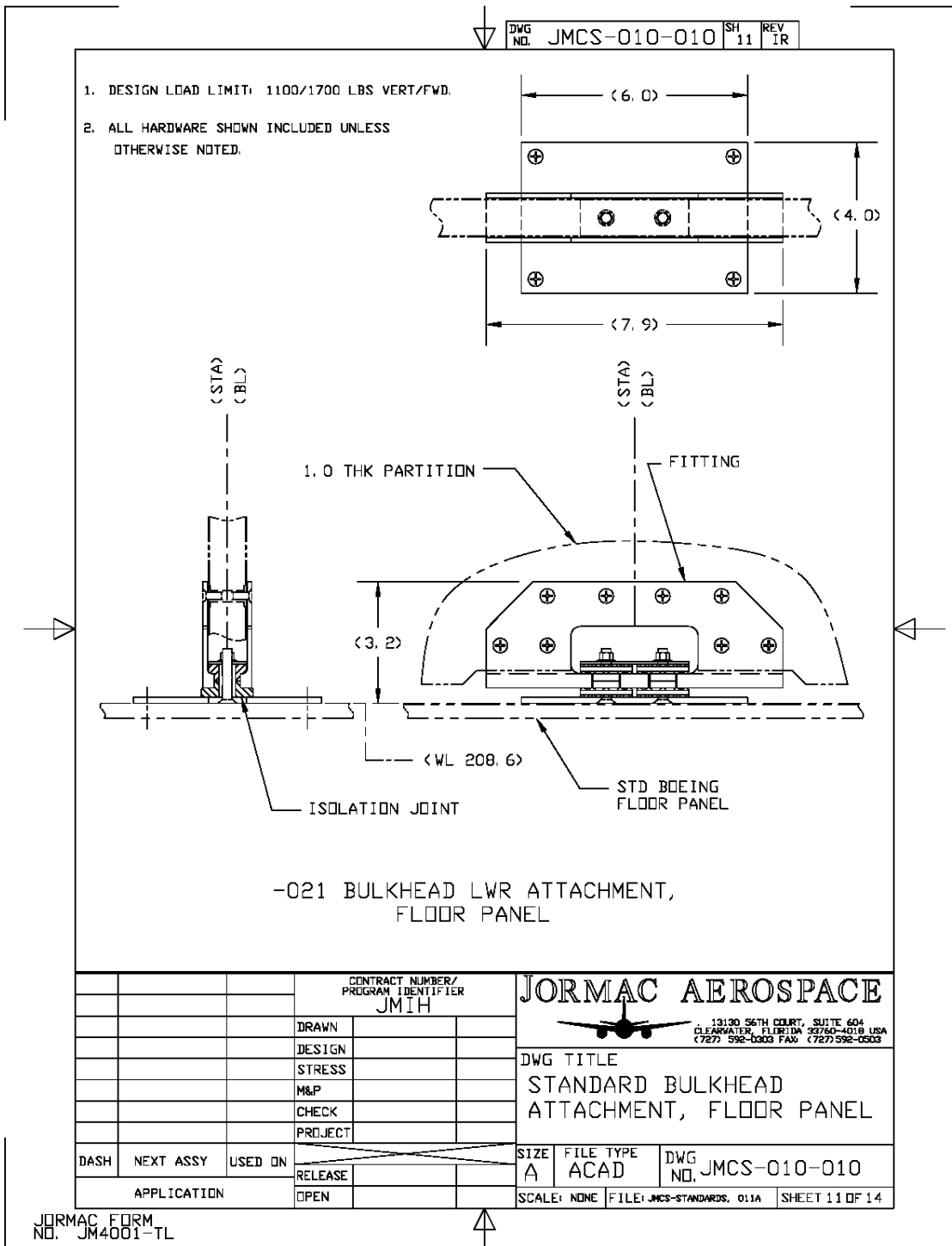

[BACK TO INDEX](#)



13130 56th Court, Suite 604
 Clearwater, Florida 33760-4018
 United States Of America

Telephone: (727) 592-0303
 FAX: (727) 592-0503

DWG NO. JMCS-010-010 SH 12 REV 1R

1. DESIGN LIMIT DEPENDENT ON PANEL CONFIGURATION. CONVENTIONAL PANEL TYPES WILL YIELD CAPABILITY OF 1200-1700 LBS.
2. ALL HARDWARE SHOWN INCLUDED UNLESS OTHERWISE NOTED.

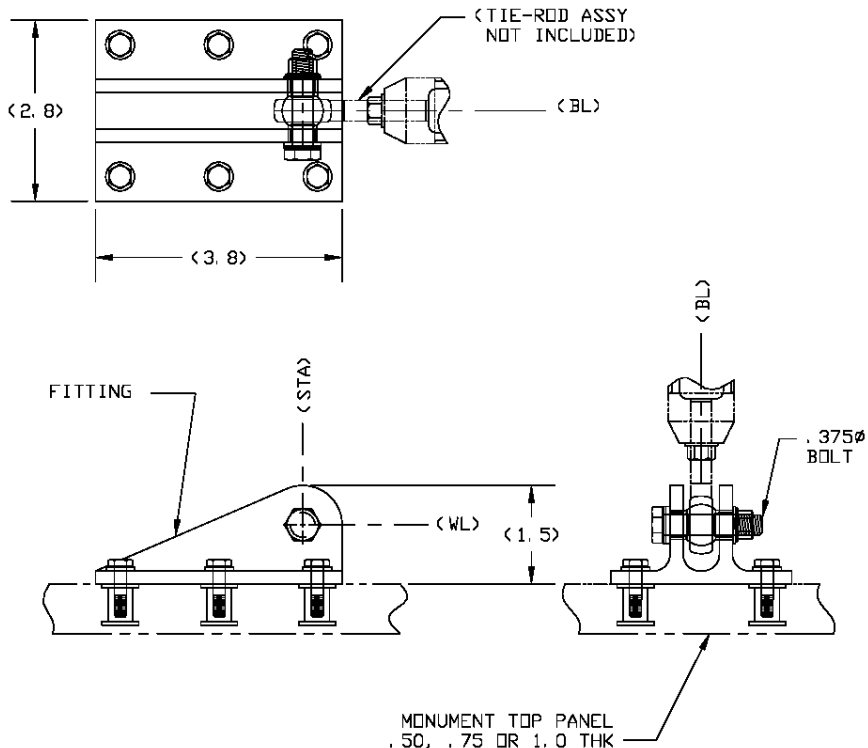

-023 MONUMENT FWD/AFT RESTRAINT,
 NON-ISOLATED

			CONTRACT NUMBER/ PROGRAM IDENTIFIER JMIH		 <small>13130 56TH COURT, SUITE 604 CLEARWATER, FL 33760-4018 USA (727) 592-0303 FAX (727) 592-0503</small>	
			DRAWN		DWG TITLE STANDARD MONUMENT ATTACHMENT	
			DESIGN			
			STRESS			
			M&P			
			CHECK			
			PROJECT		SIZE A FILE TYPE ACAD DWG NO. JMCS-010-010	
DASH	NEXT ASSY	USED ON	RELEASE		SCALE: NONE FILE: JMCS-STANDARDS_012A SHEET 12 OF 14	
APPLICATION			OPEN			

JORMAC FORM
 NO. JM4001-TL

[BACK TO INDEX](#)



13130 56th Court, Suite 604
 Clearwater, Florida 33760-4018
 United States Of America

Telephone: (727) 592-0303
 FAX: (727) 592-0503

DWG NO. JMCS-010-010 SH 13 REV 1R

1. DESIGN LOAD LIMIT: 1300-2000 LBS FOR TIE ROD ANGLES UP TO 45°.
2. ALL HARDWARE SHOWN INCLUDED UNLESS OTHERWISE NOTED.
3. STRUCTURAL INTEGRITY OF ADAPTER PLATE INSTL. DEPENDS ON ANGLE ϕ AND MUST BE ADDRESSED SEPARATELY.

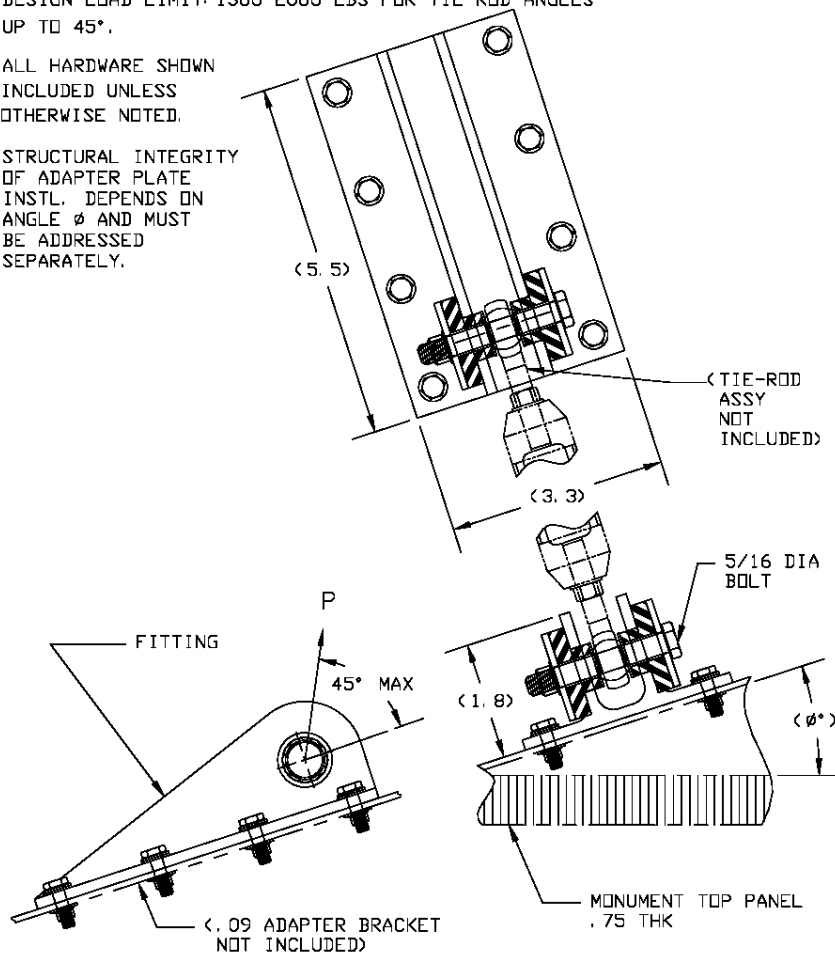

-025 MONUMENT FWD/AFT ATTACH, ADAPTER PANEL

			CONTRACT NUMBER/ PROGRAM IDENTIFIER JM1H		JORMAC AEROSPACE  <small>13130 56TH COURT, SUITE 604 CLEARWATER, FL 33760-4018 USA (727) 592-0303 FAX: (727) 592-0503</small>		
			DRAWN				
			DESIGN		STANDARD MONUMENT		
			STRESS		ATTACHMENT		
			M&P				
			CHECK				
			PROJECT				
DASH	NEXT ASSY	USED ON	RELEASE		SIZE	FILE TYPE	DWG NO.
			OPEN		A	ACAD	JMCS-010-010
APPLICATION					SCALE: NONE	FILE: JMCS-STANDARDS_013A	SHEET 13 OF 14

JORMAC FORM
 NO. JM4001-TL

[BACK TO INDEX](#)



13130 56th Court, Suite 604
 Clearwater, Florida 33760-4018
 United States Of America

Telephone: (727) 592-0303
 FAX: (727) 592-0503

DWG NO. JMCS-010-010 SH 14 REV 1R

1. DESIGN LIMIT DEPENDENT ON PANEL CONFIGURATION. CONVENTIONAL PANEL TYPES WILL YIELD A CABABILITY OF UP TO 1500 LBS.
2. ALL HARDWARE SHOWN INCLUDED UNLESS OTHERWISE NOTED.

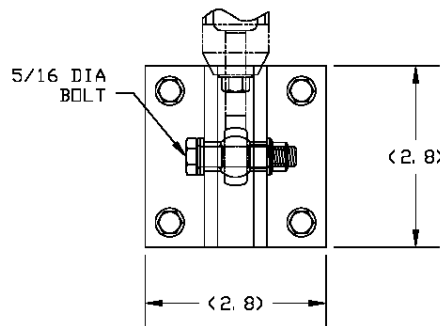
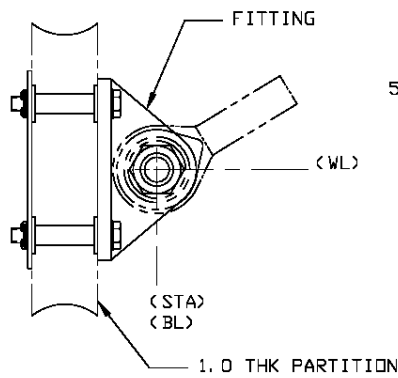
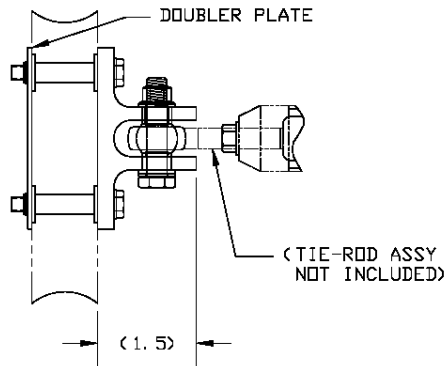

-027 UPR BULKHEAD ATTACHMENT,
 NON-ISOLATED

			CONTRACT NUMBER/ PROGRAM IDENTIFIER JMTH		JORMAC AEROSPACE 13130 56TH COURT, SUITE 604 CLEARWATER, FL 33760-4018 USA (727) 592-0303 FAX: (727) 592-0503	
			DRAWN		DWG TITLE STANDARD BULKHEAD ATTACHMENT, NON-ISOLATED	
			DESIGN			
			STRESS			
			M&P			
			CHECK			
			PROJECT		SIZE A FILE TYPE ACAD DWG NO. JMCS-010-010	
DASH	NEXT ASSY	USED ON	RELEASE		SCALE: NONE FILE: JMCS-STANDARDS_014A SHEET 14 OF 14	
APPLICATION			OPEN			

JORMAC FORM
 NO. JM4001-TL

[BACK TO INDEX](#)